

PLAN VIEW

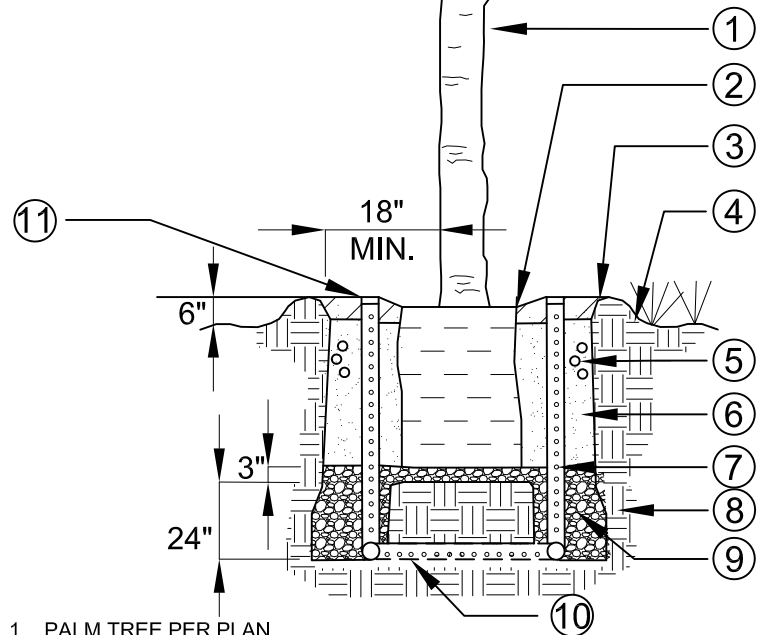

- 1. PALM TREE PER PLAN
- 2. 3-INCH DEPTH BARK MULCH INSIDE BASIN - TAPER TO 1-INCH DEPTH AT ROOT CROWN
- 3. EARTH WATERING BASIN (TO REMAIN)
- 4. FINISH GRADE (SET TOP OF ROOTBALL 4 INCHES ABOVE FINISH GRADE)
- 5. PALM FERTILIZER SPIKES (1 EA. PER 4 INCHES OF TRUNK DIA.)
- 6. WASHED SAND BACKFILL - REFER TO SPECIFICATIONS
- 7. 4-INCH PERF. SDR 35 VERT. DRAIN PIPE W/FILTER SOCK (SEE PLAN VIEW ABOVE) - 6 INCHES FROM ROOTBALL
- 8. UNDISTURBED NATIVE SOIL (TYP).
- 9. 27 INCH DEPTH (3/4-INCH CRUSHED ROCK)
- 10. 4-INCH PERF HORIZ. SDR 35 DRAIN PIPE W/FILTER SOCK (SEE PLAN VIEW ABOVE)
- 11. 4-INCH RUBBER JIM CAP W/S.S. CLAMP
- 12. 4-INCH DRAIN TEE
- 13. 4-INCH DRAIN ELL (4X)

**SECTION
NO SCALE**

- NOTES:
- 1. ALL BACKFILL TO BE WATER JETTED DURING PLANTING.
 - B. ALL FRONDS TO BE BUNDLED W / BIODEGRADABLE TWINE PRIOR TO PLANTING.
 - C. ALL BREATHER AND BUBBLER TUBES SHALL HAVE FILTER WRAP.

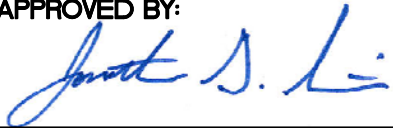
APPROVED BY:

 4/24/15
 DIRECTOR OF PUBLIC WORKS DATE
 JONATHAN GEORGE SMITH

| REVISION | BY: | APPROVED | DATE |
|----------|-----|----------|------|
| | | | |
| | | | |



CITY OF MENIFEE

**PALM TREE
PLANTING**

STANDARD PLAN NO. 1307.09 | SHEET 1 OF 1